



**World Rule Book V98**

**CABLE WAKEBOARD & WAKESKATE  
Effective from 1st January 20232**

International Waterski & Wakeboard Federation  
Cable Wakeboard Council  
All Communications via: [Office@cablewakeboard.net](mailto:Office@cablewakeboard.net)

# Rule book by the Cable Wakeboard World Council of the International Waterski & Wakeboard Federation.

## Table of Contents

<b>1. GENERAL</b>	<b>3</b>
<b>2. SAFETY AND RIDERS' EQUIPMENT</b>	<b>3</b>
<b>3. ENTRY REQUIRMENTS FOR CONFEDERATION AND WORLD CHAMPIONSHIPS</b>	<b>4</b>
<b>4. CATEGORIES / DIVISIONS</b>	<b>5</b>
<b>5. HEAT SYSTEM / RUNNING ORDER</b>	<b>7</b>
<b>6. COMPETITON AREA</b>	<b>8</b>
<b>7. TOW LINES</b>	<b>8</b>
<b>8. FEATURES</b>	<b>8</b>
<b>9. FORMAT</b>	<b>9</b>
<b>10. JUDGING CRITERIA / SCORING</b>	<b>10</b>
<b>11. TEAM SCORING AT CONFEDERATION AND WORLD CHAMPIONSHIPS</b>	<b>11</b>
<b>12. PROTESTS</b>	<b>12</b>
<b>13. SCHEDULE CHANGES</b>	<b>12</b>
<b>14. OFFICIALS – CLASSIFICATION, ROLES &amp; DUTIES</b>	<b>12</b>
<b>15. COMPETITIONS</b>	<b>14</b>
<b>16. RANKING LISTS</b>	<b>16</b>
<b>APPENDIX A : HEAT SYSTEM</b>	<b>18</b>
<b>APPENDIX B : START LISTS /RUNNING ORDER</b>	<b>20</b>
<b>APPENDIX C : FEATURE EXAMPLES</b>	<b>23</b>
<b>APPENDIX D : RANKING POINTS</b>	<b>24</b>
<b>APPENDIX E : SEATED CATEGORY SPECIFIC RULES</b>	<b>25</b>
<b>APPENDIX F : VIRTUAL OR ONLINE COMPETITIONS</b>	<b>27</b>

## 1. GENERAL

**1.1 Applicability of the Rules:** The rules set forth herein govern wakeboard and wakeskate competitions sanctioned by the Cable Wakeboard World Council (CWWC) of IWWF and apply to all PHYSICAL international events worldwide. VIRTUAL events are covered in the APPENDIX ~~FG~~. It is requested that Federations establish rules as close to these rules as possible. Whenever the masculine is used, the same shall be construed as meaning the feminine where the context so requires.

**1.2 Exceptions to the Rules:** Where compliance with the rules is not feasible, the Chief Judge shall with the approval of the majority of the judges, make the necessary changes. Such changes will be announced at a riders' or team captains' meeting, and by posting. The Chief Judge shall send a report to the CWWC to explain these changes to the rules. Where the rules are definite and feasible, a vote of the judges to decide whether to enforce any provision is prohibited.

**1.3 Drug Testing:** All competitors must agree to be subject to doping control. Specific policies and procedures regarding doping control shall be detailed in the Medical Regulations of the International Waterski & Wakeboard Federation.

**1.4 Un-sportsmanlike Conduct:** Any rider (or his representative) or official whose conduct is deemed unsportsmanlike or whose conduct may cause discredit to the CWWC or the IWWF, either on or off the competition site, before, during, or after the competition, may be disqualified from all or part of the competition including completed events and/or be subject to a fine to be determined by the CWWC, by a two-thirds majority vote of the judges. Any and all infractions can also be punishable by disqualification of the whole team or deduction of a number of points from the overall team score.

Unsportsmanlike conduct includes, but is not limited to: use of vulgar language in public, public tantrums, not riding to fullest potential, failure to attend designated functions or events, consuming alcoholic beverages during the competition, competing under false pretences, concealing significant injuries or health problems.

## 2. SAFETY AND RIDERS' EQUIPMENT

**2.1** All competitions must have an appointed CWWC Official present for the entire event who is in charge to supervise the safety measures.

**2.2** The Chief Judge and CWWC Official will check the entire site to ensure the competition can be carried out as safely as possible, especially when the site is built only for the competition. The Chief Judge must check all features before the official training or nominate a suitable official to do this.

**2.3** The competition organiser is responsible for any injuries as a result of the use of the cable and the features or any other equipment that would normally be available to the public in the event of an accident.

**2.4** A ~~F~~irst Aid team, including a water rescue team, must be on site for all CWWC Sanctioned competitions. A rescue boat/jet-ski with a stretcher must be in a suitable position to assist injured riders. Pool events are not required to provide a safety boat.

## 2.5 Concussion Protocol

Any athlete that sustains a head injury after a suspicious fall shall be subject to a concussion assessment using the IWWF [On-Water Concussion Assessment Recognition Tool \(OWCRT\)](#). If the assessment is negative, the athlete will be allowed to complete the remainder of the event. If the assessment is positive, the athlete will be returned to the starting dock where a second assessment using the OWCRT will be administered by an Event Official. If the assessment is again positive for a second time, the athlete will be removed from competition and entered into a six phase ~~s~~ brain recovery program which is part of the IWWF Concussion Protocol. The competition should be put on hold while both assessments are being carried out.

~~In the case of sports divisions, where there are no event officials on the water, t~~The 1st OWCRT should ideally be done by the safety person and the 2nd OWCRT by another official (it can be anyone). Once a decision has been made by these two officials, using the OWCRT, it cannot be overruled by anyone.

In all cases, the ~~Technical Officer / Chief Judge~~~~Safety Director~~ shall submit an [Incident Report](#) if the Athlete is deemed to have sustained a concussion using the OWCRT.

All IWWF National Federations shall implement a Concussion Protocol of their own for use at events that are outside the remit of the IWWF. No National Federation shall allow an athlete who has been diagnosed with concussion to take part in further competitions until the six phase ~~s~~ brain recovery programme has been completed and the athlete declared safe to compete.

**2.6** All participants ride at their own risk; they are expected to pay attention to any potential site specific risks and to perform a routine within their abilities.

**2.7** A rider is fully responsible for his personal equipment. Equipment should be fit for purpose and therefore riders' personal equipment may be subject to the approval of the ~~Chief Judge~~ ~~and CWWC Official~~.

**2.8** Only wakeboards and wakeskates will be allowed. Both must float.

**2.9** All competitors must wear a life vest. It is the responsibility of each rider to ensure their life vest meets the following specifications:

- It must float the rider
- It must be constructed so as to provide adequate protection from impact damage to the ribs and internal organs.

**2.10** Riders must wear a suitable well fitted helmet in the course. If a rider performs his routine without a helmet, he will be disqualified from the competition.

**2.11** Communication to a rider with any electronic device during his routine is not allowed.

**2.12** Drones are only allowed in designated areas and allowed by the Chief Judge and [highest level of Technical Officer on site](#)~~CWWC Official~~.

## 3. ENTRY REQUIRMENTS FOR CONFEDERATION AND WORLD CHAMPIONSHIPS

**3.1 Rider Eligibility:** For all riders participating at the Confederation or World Championships, the IWWF Rules of Eligibility apply.

**3.2 All riders are required to hold an IWWF License.** This will be included in the entry fee during 202~~32~~ and administered by the Cable Wakeboard Council for 202~~32~~~~Only~~.

**3.3 Minimum requirements:** are 800 points for U18, Open and +30, and 400 points for all other categories on the rolling CWWC World Ranking list the day the competition starts. Additionally, each Federation can enter max. 2 riders per gender per category with no minimum requirements (wildcard). A Rider can only use one wildcard per competition.

The minimum amount of points can be reached by adding points from higher categories, as follows:

- U14 can add points from U18 and Open to be able to start in U14
- U18 can add points from Open to start in U18
- +30 can add points from Open to start in +30
- +40 can add points from +30 and Open to start in +40

FOR PANAM and AO Championships the point requirement will be half, so 400 points Open, U18 & +30 and 200 Points for U14 and +40.

~~**COVID-19 provision, extended for 2022 Confederation and World Champs: 100 points are required for all categories, with no exceptions, 2 wildcards remain.**~~

**3.4** The host country of a Confederation or World Championship is allowed to enter a total of 2 extra riders per competition without meeting the minimum requirements.

**3.5 Competition Entry:** All riders must be registered through their respective Federation. Federations will decide the criteria for the riders' entry. There is currently no restriction to the number of riders per nationality.

**3.6** In order to hold a Confederation or World Titled event in a discipline/category there must have been at least 5 international registered events completed prior to the next announcement.

~~**3.6**~~

~~**3.7** There will be the The following Championships in 2022 are organised:~~

- **World, PANAM and AO Confederation Championships (for all categories)**
  - **Wakeboard:** Open Men, Open Women, U14 Boys, U14 Girls, U18 Men, U18 Women, +30 Men, +30 Women, +40 Men, +40 Women
  - **Wakeskate:** Open Men, Open Women, U18 Men, U18 Women
  - **Seated:** Open Men & Women
- **E&A Confederation Open Championships (for five categories)**
  - **Wakeboard:** Open Men, Open Women
  - **Wakeskate:** Open Men, Open Women
  - **Seated:** Open Men & Women
- **E&A Confederation Youth & Senior Championships (for ten categories):**
  - **Wakeboard:** U14 Boys, U14 Girls, U18 Men, U18 Women, +30 Men, +30 Women, +40 Men, +40 Women
  - **Wakeskate:** U18 Men, U18 Women

The team scoring for all events is under point 11.

## 4. CATEGORIES / DIVISIONS

### 4.1 ~~2023~~ Categories

**Wakeboard and Wakeskate:**

**U11:** (11yrs or Under), Minis (Girls& Boys): The last year a rider is allowed to compete in this category is the year of their 11<sup>th</sup> ~~B~~irthday. (For 202~~3~~, it means that the rider has to be born in 201~~2~~ or later)

U11 Category will only be used for National level events and ranking.

Under 11s cannot compete in an international Event. The minimum age for a competitor in an International Event is 11yrs.

**U14:** (14yrs or Under), Boys & Girls: The last year a rider is allowed to compete in this category is the year of their 14<sup>th</sup> Birthday. (For 202~~3~~, it means the rider has to be **born between 200~~9~~ – 201~~2~~**, but they must have reached their 11<sup>th</sup> ~~B~~irthday by registration day of the competition).

**U18:** (18yrs or Under), Junior Men & Women: The last year a rider is allowed to complete in this category is the year of their 18<sup>th</sup> Birthday. (For 202~~3~~, it means the rider has to be **born between 200~~5~~ – 201~~2~~**, but they must have reached their 11<sup>th</sup> ~~B~~irthday by registration day of the competition).

**Open Men, Open Women:** No age restriction

**+30:** Masters Men & Women: The first year a rider is allowed to compete in this category is the **year of their 31<sup>st</sup> Birthday**. (For 202~~3~~, It means the rider has to be born in 199~~2~~ or before).

**+40:** Veterans Men and Women: The first year a rider is allowed to compete in this category is the **year of their 41<sup>st</sup> Birthday**. (For 202~~3~~, it means the rider has to be born in 198~~2~~ or before).

**Seated:** Open Men & Women : No age restriction.

*To clarify: a rider born in 201~~2~~ can compete in U11, U14, U18 or Open Categories, or a rider born in 200~~5~~ can compete in U18 or Open. It is the same for +30 & +40: a rider born in 197~~8~~ can choose to complete in +40, +30 or Open.*

**4.2** The Cable Wakeboard World Council will ensure that all riders' passports are checked for verification of age.

**4.3** U11 Categories will only be used for National Level events and rankings. Only riders born in 201~~2~~ or before can take part in International Events. This means a rider born in 201~~3~~ or later can't take part in any International Event.

- A rider born in 201~~2~~ can start in U11 at National Events, but they must have reached their 11<sup>th</sup> ~~B~~irthday to compete in an International Event at the event registration.
- The minimum age of a Rider at any International Event is 11yrs

**4.4** For International Titled Events there will be a minimum of 6 ~~R~~iders required to open a category, with the exception of +30 Women, +40 Men and Women & ~~U18Junior~~ Wakeskate where 4 riders are required. In both cases, at least three different nationalities will be required to open a category. The organiser will inform all participating Federations as soon as feasibly possible if there are insufficient riders within a category.

**4.5** For all other International Events there will be a minimum of 3 ~~r~~iders required to open an age category. \* Open Categories are not AGE related.

- 4.6** For all International Events, there will be only ~~Junior~~ U18 and Open Categories in Wakeskate, and only Open in Seated.
- 4.7** Double Starts at a competition are not allowed. Starting in Wakeboard and Wakeskate is not classed as a double start
- 4.8** For the Seated Category, there must be at least two riders to open the category. To Open both Men and Women categories, there must be at least two riders in each

## 5. HEAT SYSTEM / RUNNING ORDER

- 5.1** Competitions will use a heat system, which can be found in the **Appendix A**. All models of starting lists and orders are highly recommended for 1,2 and 3 Star events, and are mandatory for 4,5 & 6 Star events.
- 5.2** In qualifying rounds, positions are determined by the current world ranking list. For the riders who are not ranked, their specific heat and running order will be determined randomly. The Chief Judge and Chief Scorer will check and adjust the start lists to ensure the heats are fair and balanced, considering the level of riding, nationalities, riders that switched categories or any other reason. The model of creating the qualifying starting lists can be found in **Appendix B**, start lists are automatically created by the scoring program but still need to be checked.
- 5.3** The riders that didn't qualify will have a Last Chance Qualification (LCQ) ~~R~~round. The heats and starting order in the LCQ will be drawn from the qualification results, as described in **Appendix B.2**.
- 5.4** In Quarter finals / Semi-finals and Finals, riders will start their 2<sup>nd</sup> run in reverse order of the first run results i.e the lowest scoring rider from the first run will start first and the highest scoring will start last.
- 5.5** With the use of the heat system, there will be instances where riders have finished in a joint position with a rider in a different heat. They will be given the same final position, whatever number of points they scored, see **Appendix B.5**
- 5.6** All riders should be ready will all their equipment when their heat is called. If a rider fails to be on hand and ready, their run is lost and the dock marshal will continue the competition with the next rider~~recommend his disqualification to the Chief Judge~~. However, the dock marshal may grant a delay of up to one minute for emergencies developing or discovered just prior to the rider's turn to ride.
- 5.7** If a rider has damaged equipment when he's due to start, the chief/head ~~J~~judge can grant him a maximum of 4 minutes to repair or replace it. The ~~C~~chief/head ~~J~~judge will have the final say as to whether the equipment can be used or not. Once the rider is on the water, he can't get a rerun if his equipment fails (for example a ripped binding, a broken board or a lost helmet).
- 5.8** In the case where a rider has been disqualified or is absent, a delay up to one-minute can be granted to the next rider in the starting order to get ready. If more than one rider is missing, the time allotted to the next rider can be increased up to one minute for each missing rider.~~# the case where a rider has been disqualified or has been scratched, a one-minute delay shall be granted to the next rider in the starting order if he is not on the starting dock at the time of disqualification. If more than one rider has been disqualified or scratched, the time allotted to the next rider shall be one minute for each missing rider.~~



**5.9** All riders must start in the qualifying round to move through the competition to the next rounds of the competition – LCQ, Quarters etc.-

A rider who is injured during the course of the competition and is unable to continue will be awarded the points relevant to his finishing point of the competition.

**5.10** Heat system for VIRTUAL competitions is different and it's covered in the APPENDIX F.

## 6. COMPETITON AREA

**6.1** The start and end of the course will be marked by visible objects

**6.2** The course should be free of obstructions other than those specifically placed for the competition. If such obstructions exist and cannot be removed, riders will be specifically advised to avoid them.

**6.3** The judges station must be situated with the best possible view of the course. The Chief judge will have the final decision on the placement of the judging station.

## 7. TOW LINES

**7.1** Only standard length lines, used for public and daily cableway use and provided by the site, shall be used.(not less than 17.80m at full size cables)

**7.2** For Two Tower systems, the line length will depend on the site specifics and has to be approved by the Chief Judge. The handle must at least touch the water in extended line mode.

**7.3** Shortening of the rope and use of extensions and different handles is not permitted.

**7.3.4** During the time of official practice and competition, all handles should be fixed so that they cannot come apart. Taping both sides of the handle is the preferred way.

## 8. FEATURES (~~Previously known as OBSTACLES~~)

**8.1** All features in the course will be used at the riders own risk.

**8.2** In the interest of safety, the Chief Judge has the right to exclude features for any reason he deems.

**8.3** There is no restriction on features allowed in competition. The only requirement is that they are laid out so riders can safely perform an equal number of air tricks and feature tricks throughout the course. It is up to the organiser and the Chief Judge to work together and decide in the best or most appropriate placement of features, considering history, new trends, common sense and safety. However, the final decision rests with the Chief Judge.

**8.4** The Bulletin for the competition has to contain a diagram of the cableway with the height, distances between the pylons, description of the course, placement and specification of features noted. The Chief Judge or a responsible Council Member should be involved in developing the optimum placement of features prior to distribution of the bulletin.

**8.5** In two tower systems, features should be accessible from both directions whenever possible. Any direction that the Officials deem dangerous will be forbidden. See **Appendix CD**

**8.6** For International competitions at small/removable cable systems that are not in regular use by the public, the organiser has to submit the drawing of the pool/lake features and the



cable for approval by the Confederation or World Council, no later than 3 Months prior to the competition.

**8.7** All features must have been in everyday use for a minimum of 14 days prior to the competition. When the site is built ~~specifically especially~~ for the competition, the 14 days rule does not apply. The position of the features must not change between the ~~Official~~ Training and the competition. Any changes requested by the organiser after the 14 days must be approved by the Chief Judge and communicated to all the registered riders of the event. The Bulletin should also be amended to reflect any changes agreed.

**8.8** For safety reasons, open water should be allowed for all air tricks. Features shall not be placed in an area where an air trick is expected or riders forced to perform an air trick over a feature.

**8.9** If a rider falls in front of a feature, he has to let go of the handle or be disqualified.

**8.10** A rider may not land an invert from the water on a feature. Doing so will result in disqualification.

**8.11** The cableway management has to ensure that all features used at the competition are safe. They must make all reasonable efforts to ensure that the features do not damage riders' boards. However, the ultimate responsibility of using a feature is with the rider.

**8.12** Where during the training or the competition a feature is found to be defective, the organiser will make every effort to fix it as quickly as possible and inform the riders of any potential problems with the feature. If a feature damaged during the competition can't be repaired quickly, it will be taken out of the water or excluded from the scoring and any heat in progress must be restarted. A decision as to whether the feature is returned later will be made by the Chief Judge in conjunction with the ~~present council~~ Officials team. The final decision rests with the Chief Judge, but the responsibility does not lie with him.

## 9. FORMAT

**9.1** ~~With the exception of the World and Confederation Championships,~~ IWWF Events can be run in any format agreed with the council in advance prior to the event registration ~~but t-~~The following format is mandatory for World and Confederation Championships.

Organisers and judging teams can decide on a different format for other National and International registered events (e.g one or two out of three runs scoring, kicker contest, best invert contest, full round contest, features only, Jam format, Head to Head etc).

**9.1** The Chief Judge together with the confederation or World Council, has to describe the format and the judging criteria and publish them at least one month prior to the competition. Examples of possible formats can be given by the CWWC.

**9.2** Riders are not required to pre-communicate their runs and are able to change their runs at will. will be judged in a FREERIDE format only.

**9.3** Riders will be judged on their equal use of both air tricks and features. Depending on the competition site and the quantity of features or possibilities to do air tricks, the weighting may be adapted by the Chief Judge and would be explained in the riders meeting,

**9.4** There will be a minimum of two rounds: a Qualification, and a Final Round. Using the heat system, Last Chance Qualifier (LCQ) and Semi-final rounds have to be included depending on the number of riders, see **Appendix A**

**9.5** One round will consist of two runs (~~passes~~) through the course, each run consisting of combinations of inverts, grabs, rotational tricks, and features. Riders may perform any tricks they choose in any order they wish. Only the best out of the two runs will be scored.

**9.6** If it is necessary to shorten the competition because of extenuating circumstances, the Chief Judge can decide to have only ~~one~~ one run in the Qualification Round, especially in a small category where all riders proceed to the finals and the qualifying run is used only to determine the starting orders of the finals.

**9.7** Judging of the routine begins when the rider enters the course and ends when the rider exits the course or falls and loses the handle.

**9.8** The speed must remain constant from the beginning of training until the end of the competition.

Where possible the normal operating speed of the cable will be published in the bulletin. Competitions on two-tower systems must be run in automatic mode, the operator is not allowed to slow down turns or tricks. The operator is not allowed to assist the rider during the competition.

## 10. JUDGING CRITERIA / SCORING

**10.1** Judging will be SUBJECTIVE only. There will be no predetermined points for any tricks.

**10.2** There must be a minimum of three judges, one of which will act as Head Judge. All must be recognised by CWWC, or National Federations for national events.

**10.3** For each judge team, Judge 1 will be the Head Judge. After the first rider in the heat, Judge 1 will set the score for the first rider. This will give a solid base for judging this particular heat.

**10.4** Judges where possible must ensure equal riding conditions are applied to all competitors. Weather conditions are not in the control of the judges and are therefore excluded from 10.4

**10.5** The scores awarded will reflect each run (~~pass~~) with a single combined score from 1-100 points. Only the best of the two runs will be taken as a result. The lower scored run will be removed.

**10.6** Each rider shall be allowed two runs through the course during which time he may perform any routine he chooses. He will be judged on two subjective categories, to arrive at a single combined score for each run. Points will be given based on technical performance and impression. Riders are encouraged to perform a smooth flowing routine with a wide variety of tricks. Each manoeuvre should be executed as cleanly as possible and taken to its limit.

### **10.7 Technical Performance**

(Level and variety of tricks performed = what did the rider perform)

Judges look for the variety and diversity of tricks in a flowing creative sequence. In the judges eyes, a better rider is one who throws a balanced variety of inverts, spins, heel side, toe side, switch, blind tricks, and handle passes etc, using both air tricks and features

### **10.8 Impression**

(Airtime, mastery, style and control of tricks = how did the rider perform)

How impressive was the routine, how big did the rider go? For sliders and kickers, how controlled and balanced is the rider? The Judges look for the degree of effort in each manoeuvre performed and in the overall run. Does the rider show his personal style in the trick performed? Is the trick grabbed, boned, tweaked, shifted? Are the tricks landed clean? How good is the body position in the air? How long was the trick grabbed? How good is the approach /cut of the tricks, the flow in the run?

#### 10.9 Calculation of scores:

Scores from the two categories (Technical performance and Impression) of a rider's routine are ~~added together~~ combined to produce a judges' total score out of 100.

There cannot be a tie between riders of the same heat.

All three judges total scores are then averaged to produce a final score out of 100 for each rider.

10.10 Repetition of tricks during one run will not be scored but a rider can repeat tricks from the first run in his second run.

10.11 Any tricks performed outside of the course or using the pull of the deflection pulley will NOT be scored.

10.12 The results may be displayed live during the competition, HOWEVER, they are not official until they are complete and approved by the Head Judge of the heat.

10.13 This judging criteria/scoring are mandatory for all international competitions. Any changes to this judging/scoring system for an international competition must be approved by the relevant Confederation or World Council. (see 9.1)

## 11. TEAM SCORING AT CONFEDERATION AND WORLD CHAMPIONSHIPS

11.1 It is encouraged to have mixed participation with men and women riders within a team, although it is not compulsory.

11.2 The following team scoring will be used for country classification at the Championships:

- World, PANAM and AO Championships: Team score will include the ~~15-B~~ best results of ~~each all~~ categoryies, with a maximum of 1 per category.
- E&A Confederation Open Championships: Team score will include the ~~5-B~~ best results of ~~all each~~ categoryies, with a maximum of 1 per category.
- E&A Confederation Youth & Senior Championships: Team score will include the ~~10~~ best results of ~~each all~~ categoryies, with a maximum of 1 rider per category.

11.3 In the event of a tie between 2 teams, the next best score will be added until there is a winning team.

11.4 The ranking point system for the relevant competition, as described in **Appendix DE**, will be used to calculate the team scoring.

~~11.4~~ 11.5 In the event of unsportsmanlike behaviour, the Technical Delegate, Competition Manager and Chief Judge have the authority to deduct an appropriate number of points from the overall team score to reflect the seriousness of the incident.

## 12. PROTESTS

**12.1** Protests shall be made to the Chief Judge only by the team captain or his representative. Protests must be made in writing, must state the reason(s) for the protest, and must be filed as soon as possible, but no later than 10 minutes after the occurrence ~~or 10 minutes after the results are announced.~~

**12.2** Protests will only be allowed for non-compliance of the rules that may have had an adverse effect on a rider. It will not be allowed for someone's disagreement with the results.

**12.3** A correction of an error in the computation of scores is no ground for a protest. If such an error occurs, it will be corrected as soon as possible.

**12.4** Protests must be accompanied by €50 (EUR) or the appropriate equivalent in local currency. This amount will be refunded if the protest is granted.

**12.5** During the run, if a rider has any reason to request a rerun, he must stop performing any further tricks and raise his hand immediately. Equipment failure as described in 5.7 is not a valid reason for a rerun. If a rider is awarded a rerun, they must complete the rerun in full, and the rerun must be completed before the next rider goes out. The rider must wait until acknowledged by the judging panel to confirm a rerun has been granted.

**12.6** Due to the subjective scoring nature and spirit of wakeboarding, video footage of any kind will not be used by judges, riders or team representatives to resolve any disputes (with the exception of the virtual competitions obviously).

## 13. SCHEDULE CHANGES

**13.1** ~~In some cases, there may be requirement to make~~ Changes to the published schedule ~~during the competition will only be made (this could be due to~~ for adverse weather or water conditions, safety or similar reason). Such changes will be announced at a riders' or team captains' meeting and by posting. It's the rider's responsibility to ensure they are aware of any schedule changes.

**13.2** The finals of each category must be completed to determine a winner. Qualification results are not enough.

**13.3** In special circumstances, if there is not enough time left to finish the full competition (due to weather conditions, features breaking or similar), the Chief Official in conjunction with the relevant Officials team ~~Council Members~~ can decide to perform one final run to determine a winner. The officials will clearly inform all riders in the finals in question in advance.

## 14. OFFICIALS – CLASSIFICATION, ROLES & DUTIES

**14.1** All Officials must be members of their respective federations.

**14.2** CWWC and Confederation Council Members are the Officials by function. They nominate the complete team of Officials for all International Events ~~the event sport part~~, which includes the Technical Officers (Technical Delegate, Competition Manager, Dock Marshals and assistants), the judging team, (Chief Judge, Head Judges, Judges) and Scorers. At large events, more officials can be nominated with additional duties required for a good coordination, such as Safety Captain, Chief of Course, or specific tasks manager for registration, cable operation,

doping control, cable security, features, safety, TV production, water rescue, medical team, team captains coordinator etc.,

**14.3** Officials achieve qualification levels by attending seminars and taking exams. CWWC and confederation council members are elected through IWWF procedures. ~~Some~~ Officials for large events are selected on their area of expertise, experience in sport and availability.

**14.4** Officials qualification levels are \*(1 Star) to \*\*\*\*\* (6 Star). Officials will need at least the same number of stars as the event.

**14.4** For International events, all officials including the scorer will require ~~the~~ education from ~~an the~~ International Seminar ~~i.e. - (Aa- S) seminar~~ conducted by CWWC approved Instructor, held in English}. The theoretical exam will have to be passed on line before the physical seminar.

**14.5** Gaining levels for Officials

Official Level	Assistant	Scorer	Judge	How to acquire level
*(1 star)	Theory 1	Theory 1+ Scoring 1	Theory 1+ Judging 1	Grassroots seminar
** (2 stars)	Theory 2	Theory 2 + Scoring 2	Theory 2 + Judging 2	Grassroots seminar
*** (3 stars)	Theory 3	Theory 3+ Scoring 3	Theory 3+ Judging 3	Advanced seminar
**** (4 stars)	Theory 4	Theory 4+ Scoring 4 + live results	Theory 4+ Judging 4	Advanced seminar
***** (5 stars)	Appointed	JDC clinic + live stream + appointed	JDC clinic + practice + appointed	CWWC JDC clinic
***** (6 stars)	Appointed	Appointed	Appointed	Appointed

<u>Official Level</u>	<u>Technical Officers</u>	<u>Scorer</u>	<u>Judge</u>	<u>How to acquire level</u>
<u>*(1 Star)</u>	<u>Theory 80% + TO1</u>	<u>Theory 80% +Scoring 1</u>	<u>Theory 80% +Judging 1</u>	<u>National or International seminar</u>
<u>** (2 Star)</u>	<u>TO2</u>	<u>Scoring 2</u>	<u>Judging 2</u>	<u>National or International seminar</u>
<u>*** (3 Star)</u>	<u>TO3</u>	<u>Scoring 3+live results</u>	<u>Judging 3</u>	<u>National or International seminar</u>
<u>**** (4 Star)</u>	<u>Theory 90%+ event assessment</u>	<u>Scoring 4 + event assessment</u>	<u>Judging 4+ event assessment</u>	<u>International Seminar+ event assessment</u>
<u>***** (5 Star)</u>	<u>Appointed</u>	<u>Scoring 5+ livestream</u>	<u>Judging 5</u>	<u>JDC Clinic + Appointed</u>
<u>***** (6 Star)</u>	<u>Appointed</u>	<u>Appointed</u>	<u>Appointed</u>	<u>Appointed</u>

It is up to the National Federations to educate National Officials. National Federations are invited to contact CWWC to ask for support to organise National or International Seminars.

International Officials are educated and granted levels in the following categories:

Technical Officer, Competition Manager / Scorer or Judge, Judge and Seminar Instructor.

Technical Officers Competition Managers can act at events as: Technical Delegate, Competition Manager, ~~(Chief) Scorer and~~ Dock Marshall, Safety Officers, Registration etc.

Judges can act at event as: Judge and Dock Marshall. Scorers can act at event as Scorer, Dock Marshall and registration officer.

Judges and Scorers have to pass theoretical and practical exams to acquire 1-4 Stars.

~~To act as a Chief Judge at an international event, one has to pass both CM and judging exam.~~

Chief Judge at international event must pass both Technical Officer and judging exams.

4 Star qualification is granted by a senior Official upon assessment at an event.

All 4 ~~s~~Star International Officials can apply to become seminar instructors. They will be appointed by the relevant Council.



All 4 Star Officials are encouraged to assist their National Federations in creating the next generation of Officials for successful events.

**14.6** Progress can be made only one level at a time. In certain cases for outstanding candidates, one more level can be achieved. All International Officials have to officiate at minimum one International event before making further progress.

**14.7** Reducing levels- for ~~\*\*\*\*~~ Officials ~~-(International 1-4 Star)~~: If in the past two seasons, a ~~4 Star~~ Official has not officiated at one International event, or a National Championship, or hasn't passed the official exam for the appropriate level, his level is reduced by one.

**14.8** Reducing levels - for ~~\*\*\*\*\*~~ Officials: A 5 ~~s~~Star Official will be reduced to 4 ~~s~~Star by the decision of the CWWC or when he hasn't officiated at five international events or national championships in the last two years, or wasn't appointed again by the CWWC.

**14.9** Reducing levels - for ~~\*\*\*\*\*~~ Officials: All 6 ~~s~~Star Officials are reduced automatically to 5 ~~s~~Star at the end of the year. New 6 ~~s~~Star Officials are appointed by the CWWC at the beginning of the year.

**14.10** Due to the fast development of the sport, all international officials have to take part in ~~/~~ ~~or~~ instruct one seminar every 4 years / retake the theoretical exam, regardless of their activity in the given period.

**14.11** All 6 ~~s~~Star officials are members of the Judges Development Commission. All 5 and 6 ~~s~~Star judges are invited by the CWWC to the Officials Clinics to develop the sport. 4 ~~s~~Star Officials can take part at such Clinics with the approval of their Federation and CWWC.

**14.12** The Chief Judge of the Competition is NOT allowed to compete in the competition.

**14.12** For any International 3 Star (and above) Competition, the Chief Judge can't be from the country where the event takes place or from the country of organizing Federation if these are different.

## 15. COMPETITIONS

**15.1** All riders in competitions must be members of their respective federations.

**15.2** Competitions are classified from \*(1 Star) to ~~\*\*\*\*\*~~(6 Stars), depending on the requirements and limitations described below.

**15.3** All national and international competitions must be properly registered with the IWWF or relevant Confederation Council, and approved by the National Federation. A bulletin in English has to be prepared for all international competitions. Bulletins must be published 30 days before the competition at the latest.

**15.4** All officials for ~~i~~nternational ~~C~~ompetitions will be appointed by the respective Confederation Council.

**15.5** Basic requirements and limitations on number of events per country:

Type	Description	Limit	Requirements & Registration deadline
6 STAR *****	World Championships	1 every 2 years	Only in even years, by contract with IWWF. Medals or Trophies will be awarded to the top three competitors in each category.
5 STAR *****	AO / E&A/ PANAM Confederation Championships	1 Event	Every <del>Y</del> year, by contract. With IWWF Confederation. The event can be split in Open and Y&S at separate locations.
5 STAR WT *****	World Trophy	1 Event	By separate contract with IWWF CWWC Council
4 STAR ****	Multi Sport Event	No limit	To register with IWWF CWWC minimum of 2 months before the event. Minimum 3 foreign Officials
4 STAR ****	International Event	No Limit	To register with IWWF CWWC minimum 2 months before the event, minimum 3 foreign Officials. Minimum Prize Money €3500 (Euro) Open, <del>U18Junior</del> & <del>+30Masters Categories</del> only
3 STAR ***	National Championships	1 Event	To register with Confederation Council minimum 1 <del>M</del> month before the event
3 STAR ***	International Event	3 Events	To register with Confederation Council minimum 2 <del>M</del> months before the event, Minimum <del>2</del> foreign Officials, Medals or Trophies. Minimum Prize Money €500 (Euro)
2 STAR **	International Event	4 Events	To register with Confederation Council minimum 1 <del>M</del> month before the event. <u>Minimum 1 foreign Official.</u> Medals or trophies.
2 STAR **	National Event	No limit	To register with Confederation Council minimum 1 <del>M</del> month before the event. Medals or trophies.
1 STAR *	International Event	5 Events	To register with Confederation Council minimum 1 <del>M</del> month before the event. <u>Minimum 1 foreign Official.</u> Medals or trophies.
1 STAR *	National Event	No Limit	To register with Confederation Council minimum 1 <del>M</del> month before the event. Medals or trophies.
Invitational Event	National or International	No Limit	To register with Confederation Council minimum 1 <del>M</del> month before the event, Min 4* Officials for International Events.

All events are published in the event calendar at [www.cablewakeboard.net](http://www.cablewakeboard.net) , with online registration for riders. All organisers have to deliver the complete start lists and results (including qualifying, LCQ and semi-final rounds) to the CWWC. International event organisers also have to



deliver a press release in English with pictures from the podium within two days of the competition.

**15.6** The use of the official scoring programme is mandatory, for all national and international ranked events.

To use the program, please write to [office@cablewakeboard.net](mailto:office@cablewakeboard.net) to get the login details for [wakeboard.info](http://wakeboard.info).

**15.7** If not specified in the Bulletin, the deadline for riders' on-site registration for all international events is minimum ~~2~~4 hours before the competition starts. (Scorer has to have enough time to prepare the heat system and publish the start lists)

**15.8** All registered competitions will have a dedicated competition page at [www.cablewakeboard.net](http://www.cablewakeboard.net) with competition information, and the live results / live feed if provided by the organiser.

**15.9** All further details in the rights and obligations of the IWWF, CWWC and competition organisers can be found in the IWWF CWWC Competition Registration Form ([Link](#))

**15.10** The following rules for holding ~~h~~international competitions on the same dates apply:

	Show	Invit	1STAR	2STAR	3STAR	4STAR	5STAR WT	5STAR Confed	World Cup	6STAR WC
Show	Y	Y	Y	Y	Y	Y	Y*	Y*	Y*	N
Invit	Y	Y	Y	Y	Y	Y	Y*	Y*	Y*	N
1STAR	Y	Y	Y	Y	Y	Y	Y*	Y*	Y*	N
2STAR	Y	Y	Y	Y	Y <del>*</del>	Y <del>*</del>	Y*	Y*	Y <del>*</del>	N
3STAR	Y	Y	Y	Y <del>*</del>	Y*	N	N	Y*	N	N
4STAR	Y	Y	Y	Y <del>*</del>	N	N	N	N	N	N
5STAR WT	Y*	Y*	Y*	Y*	N	N	N	N	N	N
5STARConfed	Y*	Y*	Y*	Y*	Y*	N	N	Y*	N	N
WORLD CUP	Y*	Y*	Y*	<del>NY</del>	N	N	N	N	N	N
6STAR WC	N	N	N	N	N	N	N	N	N	N

Y\* = Yes if in another Confederation

**15.11** In line with IWWF rules and IOC recommendations, all events with prize money must have an equal split between genders or at least the equal podium.

## 16. RANKING LISTS

**16.1** CWWC Ranking lists are produced for all age categories. A rider can start in a higher category at any competition and he'll be awarded the appropriate number of points in that category. Riders will be ranked only in the age categories where they earned points.

Example: a girl U14 wins the 4\* international competition in Open category and the Confederation champs in U14 category. She will be ranked in both Open Women and U14, but only with the points she earned in that particular category (600 in Open Women category and 800 points in U14 category).

**16.2** The points for the CWWC Ranking lists will be awarded for competitions of 1-6 ~~s~~5Stars with the system of awarding points as described in the **Appendix ~~D~~E**.

**16.3** In the occurrence of more categories of the same age and gender (e.g. Amateur Men & Pro Men), placements of advanced category are followed by the lower category. This rule applies only for 1 and 2 ~~Star~~~~TAR~~ Events. ~~Rankings from Amateur Categories will not be included in the World Rankings.~~

**16.4** All ranking lists are published on cablewakeboard.net.

**16.5** CWWC World Rankings will include all international 1-6 stars competitions and National Championships with the 6 best results for every rider in every age category, except U11. Foreign riders taking part at any Nationals or National competitions will not get the related Ranking points, and the IWWF Rules of Eligibility will be applied.

**16.6** CWWC National Rankings will include all national and international 1-6 stars competitions with the 6 best results for every rider in every age category.

~~16.7 — CWWC Annual World and National Rankings are calculated for a calendar year (1 January till 31 December~~

~~16.8~~**16.7** CWWC Rolling World and National Rankings are calculated for the period of last 12 months at any given date.

~~16.9~~**16.8** The expiration dates of the event results are as follows:

Worlds and Confederation Championships ranking points are valid until the next competition of a kind (this can be less than 12 months), or if the next competition wasn't held in the following two years, results expire on 31<sup>st</sup> March of the third year.

*Example 1: World Champs were held in November 2016. As they ~~are~~ held every even years, the next World Champs were scheduled for February 2019, so the results were valid for 27 months (until the next competition of the kind).*

*Example 2: E&A Confederation Champs were held in November 2017 and in August 2018. When 2018 results were included, 2017 results expired even though it had been less than 12 months.*

~~*This stops riders that competed. Otherwise riders that took part at both Champs Championships from having a large point advantage would be in big advantage until November when 12 months period expires.*~~

*Example 3: A Confederation Champs were held in November 2017. In 2018 and in 2019 there were no Champs in that Confederation. The ranking points expired on 31 March 2020.*

National Champs ranking points are valid until the next competition of a kind (this can be less than 12 months), or if the next competition wasn't held in the following year, results expire on 31 March of the year after.

*Example: National Champs were held in September 2017. In 2018 there were no Nationals in that country. The ranking points expired on 31 March 2019.*

All other events - International and National competitions 1-5 stars ranking points are valid for 12 months.

APPENDIX A : ~~(HEAT SYSTEM)~~**HEAT SYSTEM Finals with 6 riders 2 QUALI 1 LCQ RUN**

No. Riders	Qual Groups	No. to final	Tot. to final	No. LCQ	LCQ Groups	No. to final	Tot. to semi final	No. Semi	Semi Groups	Tot. to final	No. Final
4	1	4	4	0	0	0				0	4
5	1	5	5	0	0	0				0	5
6	1	6	6	0	0	0				0	6
7	1	7	7	0	0	0				0	7
8	2	2	4	4	1	2				2	6
9	2	2	4	5	1	2				2	6
10	2	2	4	6	1	2				2	6
11	2	2	4	7	2	1				2	6
12	2	2	4	8	2	1				2	6
13	3	1	3	10	3	1				3	6
14	3	1	3	11	3	1				3	6
15	3	1	3	12	3	1				3	6
16	3	1	3	13	3	1				3	6
17	3	1	3	14	3	1				3	6
18	3	1	3	15	3	1				3	6
SEMIFINAL 19 TO 36. Riders	Qual Groups	No. to semi final	Tot. to semi final	No. LCQ	LCQ Groups	No. to semi final	Tot. to semi final	No. Semi	Semi Groups	No. to final	No. Final
19	4	2	8	11	2	2	4	12	2	3	6
20	4	2	8	12	2	2	4	12	2	3	6
21	4	2	8	13	4	1	4	12	2	3	6
22	4	2	8	14	4	1	4	12	2	3	6
23	4	2	8	15	4	1	4	12	2	3	6
24	4	2	8	16	4	1	4	12	2	3	6
25	6	1	6	19	6	1	6	12	2	3	6
26	6	1	6	20	6	1	6	12	2	3	6
27	6	1	6	21	6	1	6	12	2	3	6
28	6	1	6	22	6	1	6	12	2	3	6
29	6	1	6	23	6	1	6	12	2	3	6
30	6	1	6	24	6	1	6	12	2	3	6
31	6	1	6	25	6	1	6	12	2	3	6
32	6	1	6	26	6	1	6	12	2	3	6
33	6	1	6	27	6	1	6	12	2	3	6
34	6	1	6	28	6	1	6	12	2	3	6
35	6	1	6	29	6	1	6	12	2	3	6
36	6	1	6	30	6	1	6	12	2	3	6

<b>QUARTERS FROM 37 TO 52No. Riders</b>	<b>Qual Groups</b>	<b>No. to quarter final</b>	<b>Tot. to quarter final</b>	<b>No. LCQ</b>	<b>LCQ Groups</b>	<b>No. to quarter final</b>	<b>Tot. to quarter final</b>	<b>No. Quarter</b>	<b>Quarter Groups</b>	<b>No. to semi final</b>	<b>No. Semi</b>	<b>Semi Groups</b>	<b>No. to final</b>	<b>No. Final</b>
37	7	2	14	23	5	2	10	24	4	3	12	2	3	6
38	7	2	14	24	5	2	10	24	4	3	12	2	3	6
39	7	2	14	25	5	2	10	24	4	3	12	2	3	6
40	7	2	14	26	5	2	10	24	4	3	12	2	3	6
41	7	2	14	27	5	2	10	24	4	3	12	2	3	6
42	7	2	14	28	5	2	10	24	4	3	12	2	3	6
43	8	2	16	27	8	1	8	24	4	3	12	2	3	6
44	8	2	16	28	8	1	8	24	4	3	12	2	3	6
45	8	2	16	29	8	1	8	24	4	3	12	2	3	6
46	8	2	16	30	8	1	8	24	4	3	12	2	3	6
47	8	2	16	31	8	1	8	24	4	3	12	2	3	6
48	8	2	16	32	8	1	8	24	4	3	12	2	3	6
49	9	2	18	31	6	1	6	24	4	3	12	2	3	6
50	9	2	18	32	6	1	6	24	4	3	12	2	3	6
51	9	2	18	33	6	1	6	24	4	3	12	2	3	6
52	9	2	18	34	6	1	6	24	4	3	12	2	3	6
53	9	2	18	35	6	1	6	24	4	3	12	2	3	6
54	9	2	18	36	6	1	6	24	4	3	12	2	3	6

## APPENDIX B : ~~{~~START LISTS /RUNNING ORDER~~}~~

The scoring system automatically creates the start lists, however it is a requirement for scorers to understand how to compile the start lists in case of ~~the~~ system failure.

### B.1 How to create Qualification start lists:

1. First check the ranking for all riders at [www.cablewakeboard.net](http://www.cablewakeboard.net) . Use only the riders ranking in the category that he is riding for your specific competition. Then sort all the riders, with the best ranked rider first.
2. Assign all unranked riders to the end of the list randomly.
3. Determine the heat system needed with Appendix A of the World Rules.
4. Start at the top of the list (with the best ranked rider) and put him into the LAST heat (D), in the last position. Now put the second best rider into the second last heat, in the last position.
5. Continue this until you have put one rider in the last position in each heat
6. Now take the next rider on the list and put them in the FIRST heat (A) in the second to last position
7. Then the next ranked rider goes into the second heat at the second to last position and so on until you have two riders in each heat.
8. Repeat previous steps until you have all riders in the groups

Example with 24 riders, 4 heats of 6 riders (the number is the rank of the rider):

<b>A</b>	<b>B</b>	<b>C</b>	<b>D</b>
21	22	23	24
20	19	18	17
13	14	15	16
12	11	10	9
5	6	7	8
4	3	2	1

### B.2 How to create LCQ or Final Start lists:

There are two principles to create LCQ or Final Start lists.

AAL (A) System: to be used when there are the same number of LCQ and Qualification heats, an even number of LCQ and Qualification heats or double of the number of Qualification as LCQ heats (for example, 2 LCQ heats and 4 Qualification Heats, or 2 Semi final Heats and 6 Qualification Heats) Snake (S) System: to be used in all other cases.

Number of LCQ Heats	Number of Qualification Heats								
	1	2	3	4	5	6	7	8	<u>9</u>
1	-	S	S	S	S	S	S	S	S
2	-	A	S	A	S	A	S	A	S
3	-	-	A	S	S	A	S	S	S
4	-	-	-	A	S	A	S	A	S
5	-	-	-	-	A	S	S	S	S
6	-	-	-	-	-	A	S	A	S
7	-	-	-	-	-	-	A	S	S
8	-	-	-	-	-	-	-	A	S

### B.3 Snake System

1. First make a seeded list with all the riders:
  - a. Take the best rider (who didn't qualify) from the last heat and put him first. Now put the best rider from the second last heat in second and so on until you have done all heats once (you should finish on heat A).
  - b. Now repeat a but in the other direction i.e. start with heat A and end with the last heat.
  - c. Repeat a and b until you have all riders in your list
2. Now you have your new seeding list you can make the LCQ lists as you did for the qualification lists. Start at point 4 of the qualification start list instructions

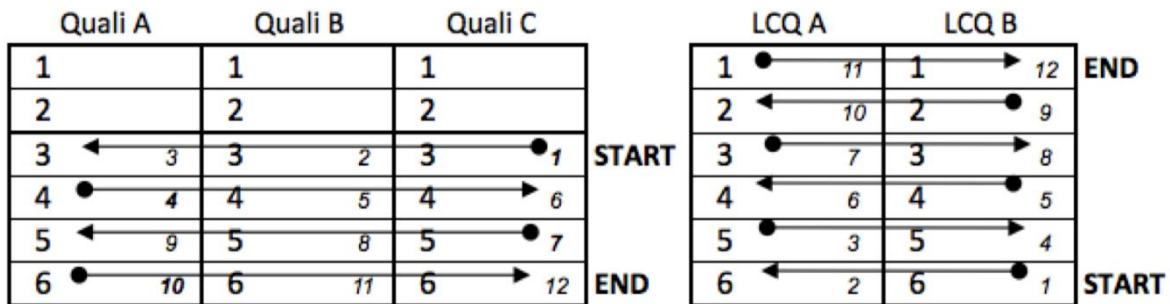

### B.4 AAL System

1. First make a seeded list with all the riders:
  - a. Take the best rider (who didn't qualify) from the last heat and put him first. Now put the best rider from the second last heat in second and so on until you have done all heats once (you should finish on heat A).
  - b. Now do the same but start with the next last heat and the next best rider. Once you have placed the rider from heat A go to the last heat and continue in the same direction.
  - c. Repeat b until you have all riders in your list.
2. Now you can split your riders in to heats.
  - a. Don't use the same system. Start at the top of the list (best placed in last heat) and put him into the LAST heat, at the last position. Now put the second best rider into the second last heat, at the last position. Continue this until you have put one rider at the last position in each heat.
  - b. Repeat step 4 until you have placed all riders (always starting with the last heat)

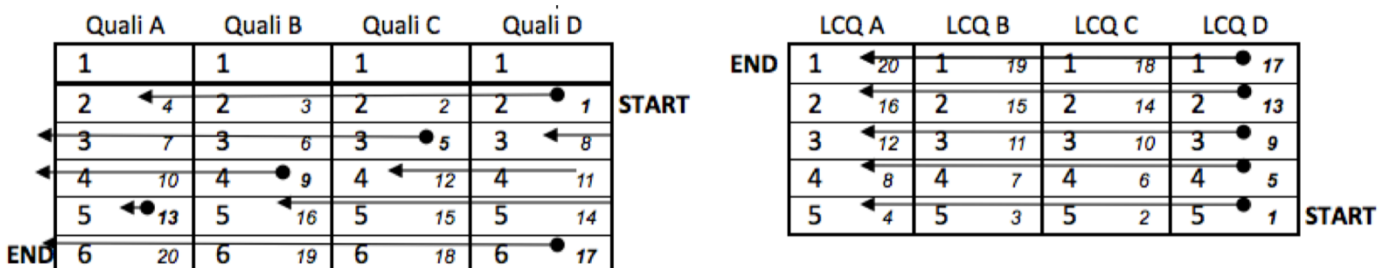

### Creating Semi-final lists by combining Qualification and LCQ Results

Decide to use either AAL or SNAKE ~~Mixing S~~system by looking at how many Qualification Heats give how many Semi-finals.

Use the system of your choice to place the Riders who qualified directly from the Qualification at the last starting places, depending of their results during Qualifications.

Then look at how many LCQ Heats you have to use and how many Semi Final Heats you have, choose the mixing system that you have to use.

Then use the system and begin by placing the best rider from the last LCQ Heat on the first remaining starting Position of the last Semi-final Heat and continue with the rest.

### B.5 Creating final placements according to the Semi-final / Final results

<p><b>SEMI-FINALS – HEAT 1</b>                      1st place                      2nd place                      3rd place                      4<sup>th</sup> place (equal to 7<sup>th</sup> Place)                      5th place (equal 9th place)                      6th place (equal 11th place)</p>	<p>1st – 3rd place advance to finals</p>	<p><b>FINALS</b> 1st place                      2nd place                      3rd place                      4th place                      5th place                      6th place</p>
<p><b>SEMI-FINALS – HEAT 2</b>                      1st place                      2nd place                      3rd place                      4thplace (Equal to 7<sup>th</sup> Place)                      5th place (equal 9th place)                      6th place (equal 11th place)</p>	<p>1st – 3rd place advance to finals</p>	

### ~~APPENDIX C – Judging tent positions~~

~~Removed as no longer relevant, and dependent on the organising site. The Chief Judge will decide on the correct placement of the judges' area.~~



## APPENDIX DC : (FEATURE EXAMPLES)

Taken from Point 2 of the rule book.

2.2 The Chief Judge and CWWC Official will check the entire site to ensure the competition can be carried out as safely as possible, especially when the site is built only for the competition. The Chief Judge must check all features before the official training or nominate a suitable official to do this.

2.3 The competition organiser is responsible for any injuries as a result of the use of the cable and the features or any other equipment that would normally be available to the public in the event of an accident.

Example of a feature that cannot be used in both directions. Vertical areas facing the rider have to be avoided (in red).

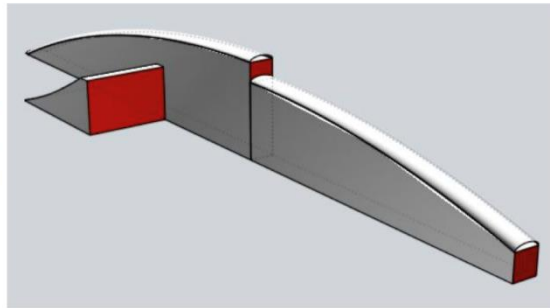

Example of a feature that can be used in both directions.

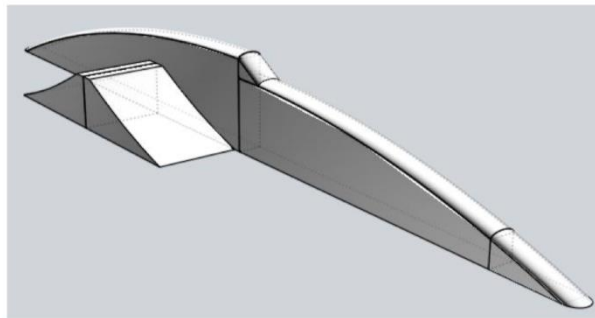

### Corrugated Pipes

The use of corrugated pipes as a sliding surface poses significant risks. Depending on their depth, each rib becomes a structural and permanent point of impact. Catching the heelside, toeside, molded fins and fins can happen at any time and cause the board to come to an abrupt stop, and the associated fall of the rider on the pipe. Due to the momentum of the rider, there is not only an impact between the body and the pipe, but also a hit on each rib of the corrugated pipe which can quickly increase the severity of the fall.

The three leading manufacturers don't use this type of material in their current ranges of features for these safety reasons.

The International Cable Wakeboard World Council (CWWC) advises strongly against the production and use of features using such pipes as sliding surfaces during public hours. It could be allowed at events and competitions, depending on the condition of the pipe and the competition field, if a special briefing is included at the Riders Meeting before the competition.

APPENDIX ~~D~~E : RANKING POINTS

	*****	*****	****	***	**	*
	6STAR	5STAR	4STAR	3STAR	2STAR	1STAR
1	1000	800	600	400	200	100
2	925	740	555	370	185	93
3	856	685	513	342	171	86
4	791	633	475	317	158	79
5	732	586	439	293	146	73
6	677	542	406	271	135	68
7	626	501	376	251	125	63
8	579	464	348	232	116	58
9	536	429	322	214	107	54
10	496	397	297	198	99	50
11	459	367	275	183	92	46
12	424	339	255	170	85	42
13	392	314	235	157	78	39
14	363	290	218	145	73	36
15	336	269	201	134	67	34
16	311	248	186	124	62	31
17	287	230	172	115	57	29
18	266	213	159	106	53	27
19	246	197	147	98	49	25
20	227	182	136	91	45	23
21	210	168	126	84	42	21
22	195	156	117	78	39	19
23	180	144	108	72	36	18
24	166	133	100	67	33	17
25	154	123	92	62	31	15
26	142	114	85	57	28	14
27	132	105	79	53	26	13
28	122	97	73	49	24	12
29	113	90	68	45	23	11
30	104	83	63	42	21	10
31	96	77	58	39	19	10
32	89	71	54	36	18	9
33	83	66	50	33	17	8
34	76	61	46	31	15	8
35	71	56	42	28	14	7
36	65	52	39	26	13	7
37	60	48	36	24	12	6
38	56	45	34	22	11	6
39	52	41	31	21	10	5
40	48	38	29	19	10	5
41	44	35	27	18	9	4
42	41	33	25	16	8	4
43	38	30	23	15	8	4
44	35	28	21	14	7	4
45	32	26	19	13	6	3
46	30	24	18	12	6	3
47	28	22	17	11	6	3
48	26	20	15	10	5	3
49	24	19	14	9	5	2
50	22	18	13	9	4	2

## APPENDIX EF : SEATED CATEGORY SPECIFIC RULES

### 2. SAFETY AND RIDERS' EQUIPMENT

2.7 Only wakeboards and kneeboards will be allowed. Both must float.

### 3. ENTRY REQUIREMENTS FOR CONFEDERATION OR WORLD CHAMPIONSHIPS

3.2 There is no minimum points requirement for the Seated category

### 4. CATEGORIES / DIVISIONS

4.1. Open Seated: No age restriction

4.4. To open the 'Seated' category, a minimum of 2 riders from 2 different nationalities is required. A minimum of 2 riders from each gender from 2 different Nationalities is required to split the category into Men and Women.

4.8 For the Seated Category, there must be at least two riders to open the category. To open both Men and Women categories, there must be at least two riders in each.

### 8. FEATURES

For seated categories, features without entrance (where an ollie is required) will be forbidden.

### 10. JUDGING CRITERIA / SCORING

Specific ratio is applied for the scoring of seated category.

The final score will be altered (multiplied) with the rider's category ratio to give his/her final score.

Category	Ratio
MP1	2.0
MP2	1.6
<u>MP3</u>	<u>1.3</u>
<u>MP4</u>	1.2
<u>ABMP5</u>	1.0

~~MP1: Athletes unable to utilize the majority of their trunk musculature. Athlete is unable to rise from knees without arm support. They lack full use of their upper extremities. Typically, they do not have adequate grip strength and may utilize their forearms or wrists to hold the handle.~~

~~MP2: Athletes able to use their upper trunk muscles to partially raise their upper body from their knees in the skiing position. Typically, they have full use of their upper extremities.~~

~~MP3: Athletes with good use of the majority of their trunk muscles. Athlete may be able to use partial abdominal musculature. Typically, they are able to raise the trunk from their knees in the~~

skiing position and have full use of their upper extremities. A complete description is available in the document "CLASSIFICATION RULES CABLEWAKEBOARDING for people with disabilities"

MP1 Riders: No controlled trunk movement (unsupported) in all planes. Little or no balance in both forward and sideways directions. Balance and movement are significantly impaired. Skier is unable to hold or maintain holding the handle with hands. Skiers have no trunk rotation and no use of abdominal muscles. Skiers in this class generally have complete tetraplegia/quadruplegia, although skiers with other diagnoses may qualify in this category.

MP2 Riders: Little or no controlled trunk movement in all planes. Balance in both forward and sideways directions significantly impaired and Riders rely on their arms to return them to the upright position when unbalanced. No active trunk rotation and no use of abdominal muscles. Riders in this class are generally quadriplegics, may be incomplete quadriplegics with more functional ability and high level paraplegics, although other diagnoses may qualify in this category.

MP3 Riders: Some partially controlled trunk movement in the forward direction, but little or no controlled sideways movement, has upper trunk rotation but poor lower trunk rotation. Riders in this category are generally mid-level break paraplegics, although Riders with other diagnoses may qualify in this category.

MP4 Riders: Good trunk movement in the forward direction to his/her knees and up again without arm support. Has good trunk rotation but limited controlled sideways movement. Riders in this category are generally lower level break paraplegics, although Riders with other diagnoses may qualify in this category.

MP5 Riders: Normal trunk movement in all directions, able to reach side to side with no limitations. Able to move hips independently. Riders in this category are generally amputees who cannot ski standing, Riders with low or incomplete spinal cord injuries with leg control and Riders with required minimum disability and who display controlled sideways (hip) movement.

Qualification criteria: only riders with a form of disability that fall under the noted categories are allowed to compete in the seated category.

## APPENDIX ~~F~~<sup>G</sup> VIRTUAL OR ONLINE COMPETITIONS

1. All events will be registered at [cablewakeboard.net](http://cablewakeboard.net) and riders will join them in order to get the final scores & ranking points.
2. Unedited videos will be uploaded to the online platform. ~~F~~<sup>G</sup>-Please mind, unedited means tricks have to be unedited (no slow motions as well), one camera for one trick, the whole trick must be clearly shown in the video, including the approach and landing. You can add sponsors to the beginning, add or edit the title and combine different footage for different tricks, or add the slow motions to the end of the video.
3. For categories of max. 18 riders there will be no heats and no LCQ's. For +18 riders standard heat system will be used.
4. Virtual / Online competitions are differentiated as:

### **LOCATION BASED EVENTS**

The approved rank of these competitions will highly depend on the travel restrictions (at this point only National events will be approved).

All local Pandemic regulations must be adhered to throughout the event.

There will be no Official practice, riders can practise during the public hours.

Organizer will ensure min. 1 hour per day for competition runs, clearly stated in the Bulletin.

If organizer requires so, riders have to book and pay the fees in advance.

The course will be in place two weeks before the start of the event.

Three riders are required to open the category.

All riders will get 2 runs for the competition, and will choose which run to upload for judging.

A dedicated Dock and Video Officials will be provided by the organizer.

All videos must be raw footage, no editing allowed, using the same camera angles for all participants. Videos will be uploaded within 12hrs of competition run taking place.

For the National Championships, the Confederation Council will appoint an independent Supervisor to ensure the rules are followed.

### **NON-LOCATION BASED EVENTS**

Organizers are welcome to surprise us with new exciting formats, riders will shoot and upload the videos themselves.

5. Organizers will compile the Competition Bulletin containing the following information:
  - Competition format explained in detail
  - Requested Rank of the event (1-4 stars, ranked, non-ranked), categories
  - Registration rules, fees and deadlines, duration of the event
  - Prizes
  - Judging criteria, including community judging (max. 10%)
6. Bulletins for proposed International events will be revised by CWWC, for National events by the relevant Confederation Councils and Judging panel will be appointed.
7. Competitions will be awarded the appropriate Rank depending on format, Prize fund, competition duration and on site Officials.
8. Final results will be published and confirmed no later than 24 hours after the competition closes online, details of each event to be listed in the bulletin.
9. Registration fees: please refer to the Registration form for details.